

# NOVA ZERO RAILING SYSTEM *ZERO*

## WATERPROOF CARPORT

### PRODUCT SHEET

#### NOVA SERIES PRODUCTS

Application: Ground & Flat Roof  
Tilt Angle: 5°-10°  
Panel Orientation: Portrait (Small Size Panel)  
Panel Type: Framed module  
Panel Length: <1755mm  
Panel Thickness: 28-50mm  
Waterproof Type: Structural Waterproof  
Material: Bracket-AL6005-T5&SUS304  
Warranty: 15 years



FAST & EASY  
INSTALLATION



COST EFFECTIVE  
SOLUTIONS



QUALITY  
ASSURED



15  
YEARS  
WARRANTY

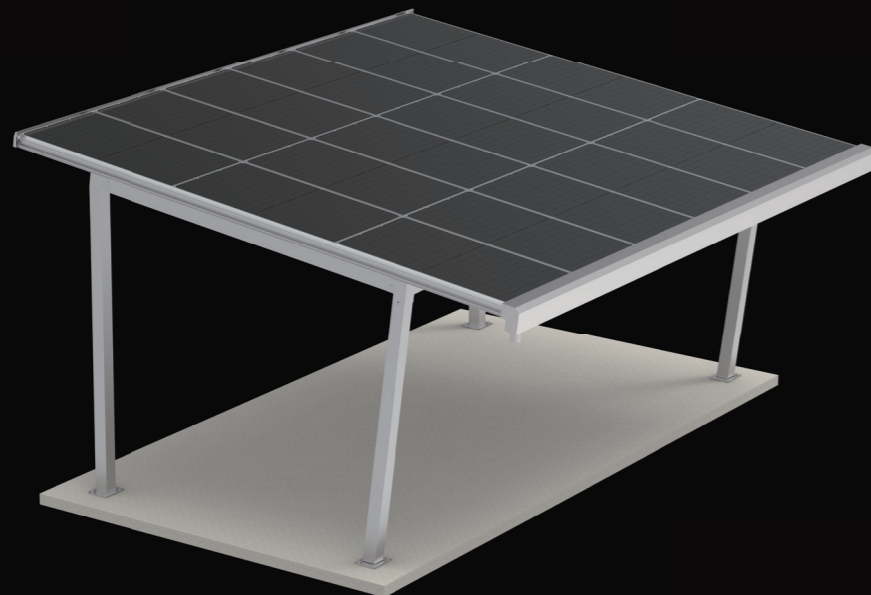

## KEY FEATURES

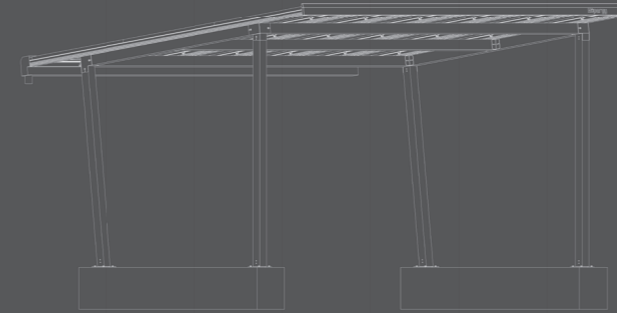

1.The NOVA ZERO Railing System - Carport, is a modularized system available in single or double carspace, with the ability to extend.

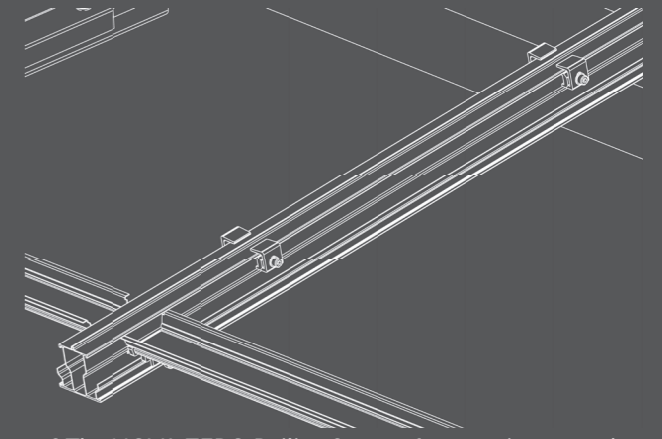

2.The NOVA ZERO Railing System features integrated water drainage channels, ensuring effective water management and preventing pooling or accumulation.

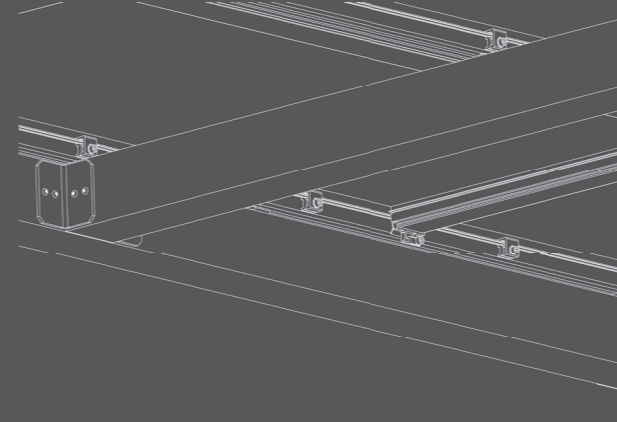

3.The strategically designed purlins feature prethreaded holes, providing convenient railing installation.

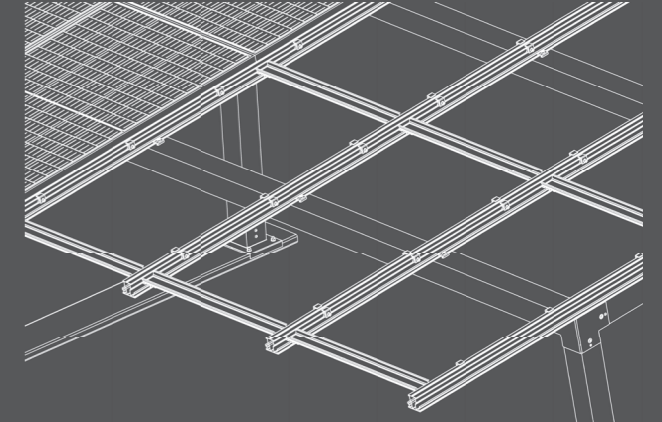

4.Our innovative guttering system is specifically engineered to ensure ZERO leakage.

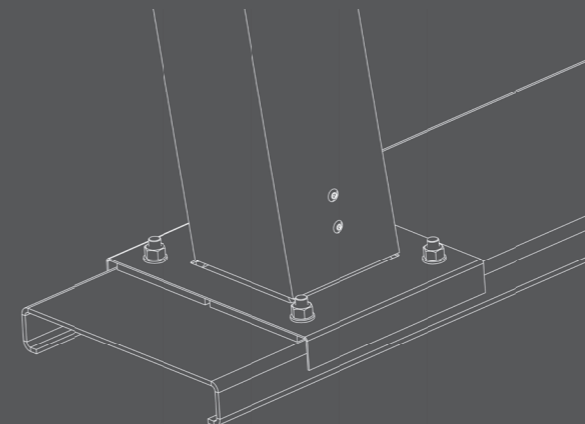

3.With preassembled upright supports, our system simplifies installation onto the foundation, streamlining the process and making it effortless.

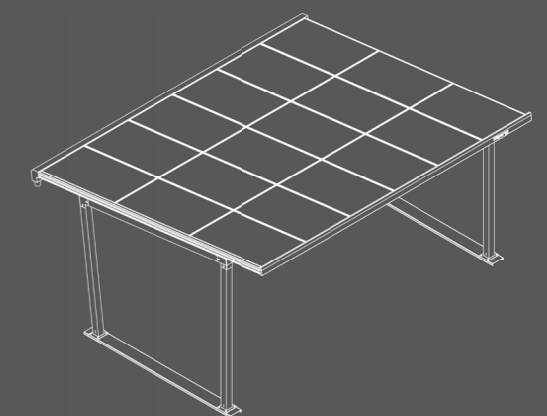

4.For streamlined plumbing, our solution includes a rear gutter that facilitates efficient water flow and drainage