

NOVA TILE ROOF SOLUTION

PRODUCT SHEET

NOVA SERIES PRODUCTS

NOVA Tile Roof Mounting Solution is designed to seamlessly integrate with virtually any tiled roof. Our extensive range of tile brackets ensures easy and secure attachment to purlins or rafters, without compromising the integrity or functionality of the tiles. Our roof brackets are available for a wide variety of tile types, ranging from traditional profile tiles to modern-day designs.



FAST & EASY
INSTALLATION



COST EFFECTIVE
SOLUTIONS



QUALITY
ASSURED



15 YEAR
WARRANTY

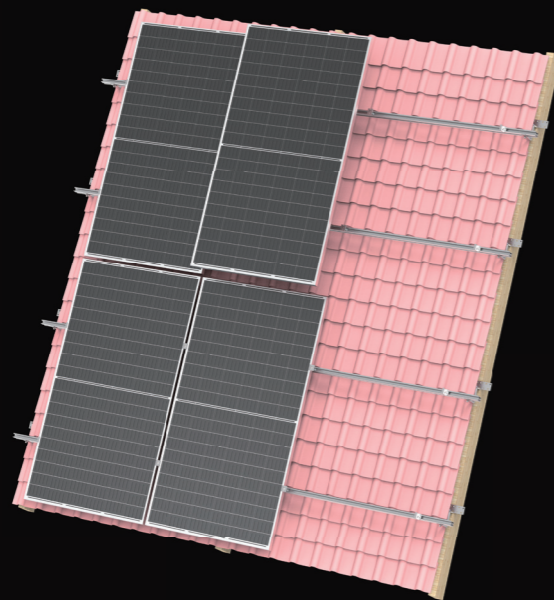

KEY FEATURES

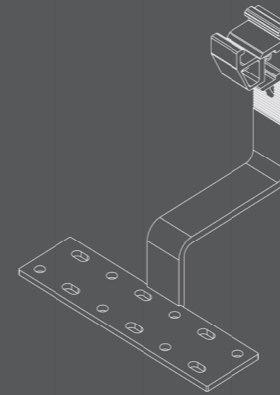

1. Constructed from high quality, structural grade alloys, ensuring corrosion resistant for durability and longevity.

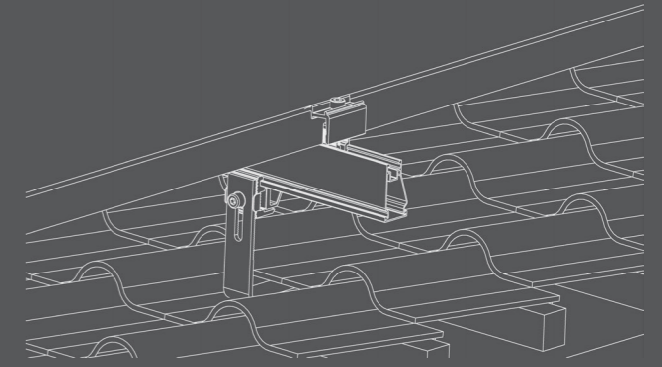

2. Available in a fixed or adjustable hook to fit a wide variety of tiles.

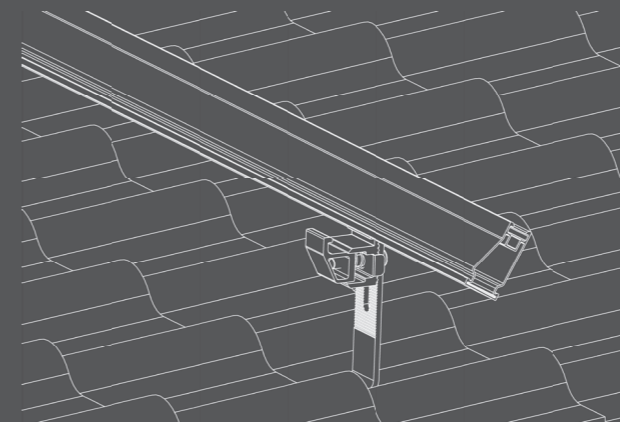

2. Unique clamp system for an effortless rail attachment.

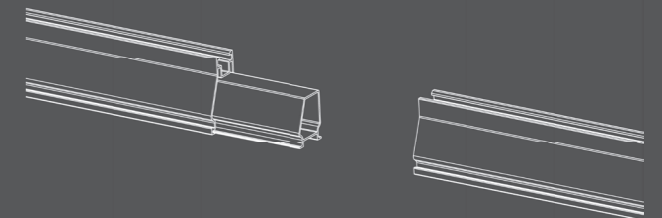

4. The internal rail joiner ensures earth continuity between rails without obstructing component attachment. It seamlessly slides inside the Nova rail, allowing for a smooth and uninterrupted join.

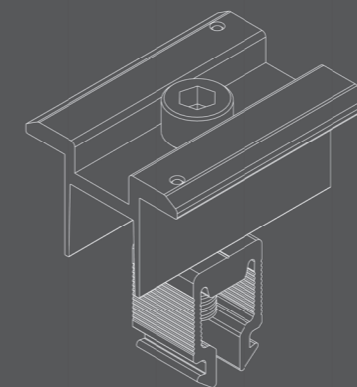

5. The NOVA panel clamps incorporate a user-friendly Clip-in design and integrated earthing pins, eliminating the requirement for an additional grounding plate.

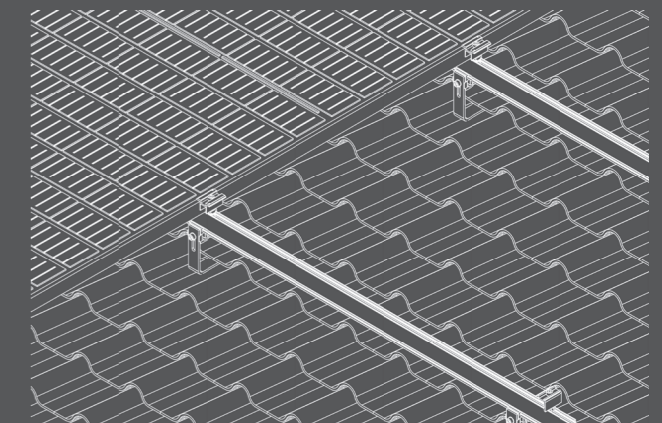

6. NOVA Panel Clamps offer a universal fit, accommodating panel thickness ranging from 30mm to 40mm.