

NOVA BALLAST SYSTEM TYPE-M

PRODUCT SHEET

NOVA SERIES PRODUCTS

Application: Flat roofs
 Tilt angle: 10°
 Panel layout: Landscape
 Panel width: 990mm-1303mm
 Panel thickness: 30-40mm
 Material: AL6005-T5&Zinc-Aluminum-Magnesium Coated Steel
 Warranty: 15 years



FAST & EASY
INSTALLATION



COST EFFECTIVE
SOLUTIONS



QUALITY
ASSURED



15 YEARS
WARRANTY

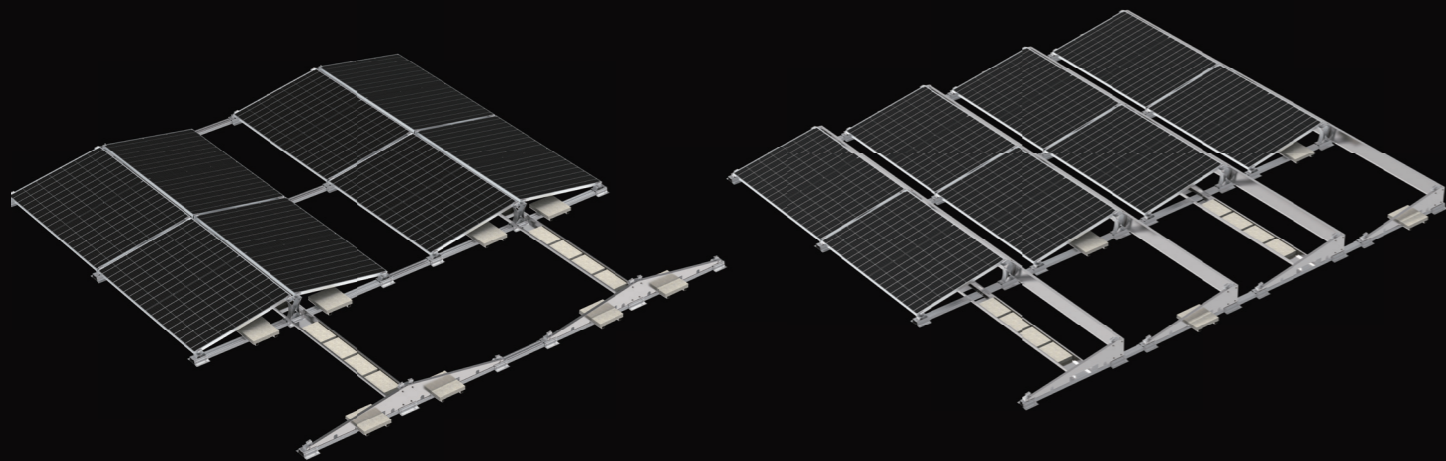

KEY FEATURES

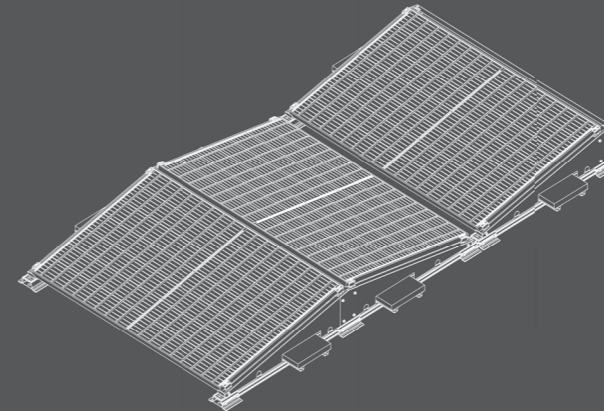

1. Modularized System, fast and labor-saving. Suitable for south north and east west orientation panel layout.

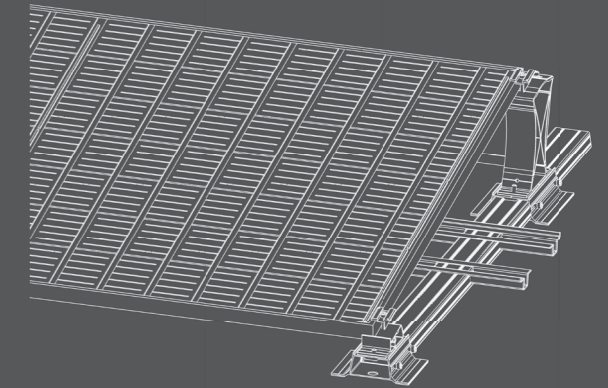

2. Strategically engineered for optimal strength and cost-effectiveness, our front and rear legs utilize triangular mechanics to maximize structural integrity without compromising value.

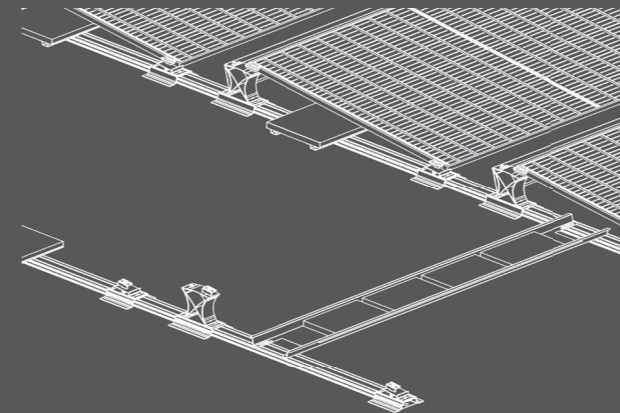

3. Enhance stability with our versatile ballast trays, designed for compatibility with various concrete types. The unique structure ensures increased stability across the entire array.

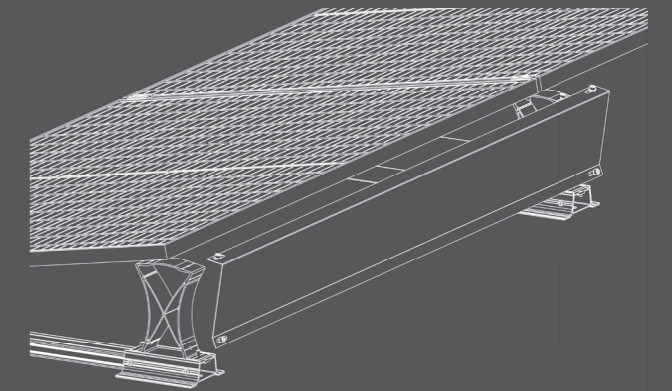

4. The front and rear legs feature prethreaded holes for wind deflector installation, enhancing array stability and ensuring the safety of the PV system.

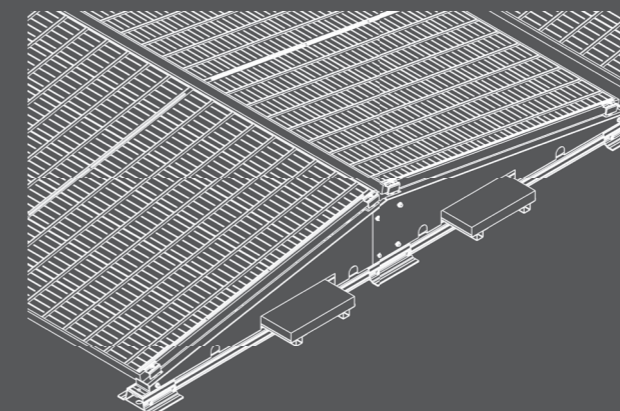

5. The short-side wind deflector conveniently accommodates cable and ballast outlets, greatly simplifying cable and ballast installation management.

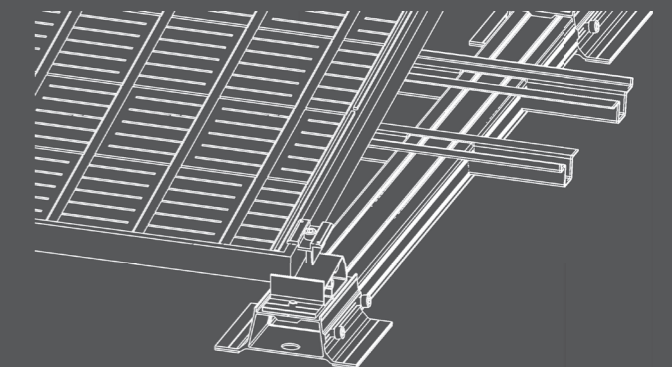

6. Our base design is uniquely crafted to provide exceptional isolation and effectively prevent vibrations.